

# User Manual

## SK202 – Contactless GbE

### 1. Overview

This document guides users how to use the SK202A/B modules. The pair of modules transmits Gigabit Ethernet signals at a distance of several centimeters in a contactless way. SK202 opens a new scene for network connection applications. This module integrates a network PHY chip and ST60 A2, a millimeter wave wireless transceiver chip, which can be simply connected to the existing Ethernet replacing a network cable. Please note is that both SK202 modules must at the same speed mode as described in section 3 of this document.

### 2. Connection method

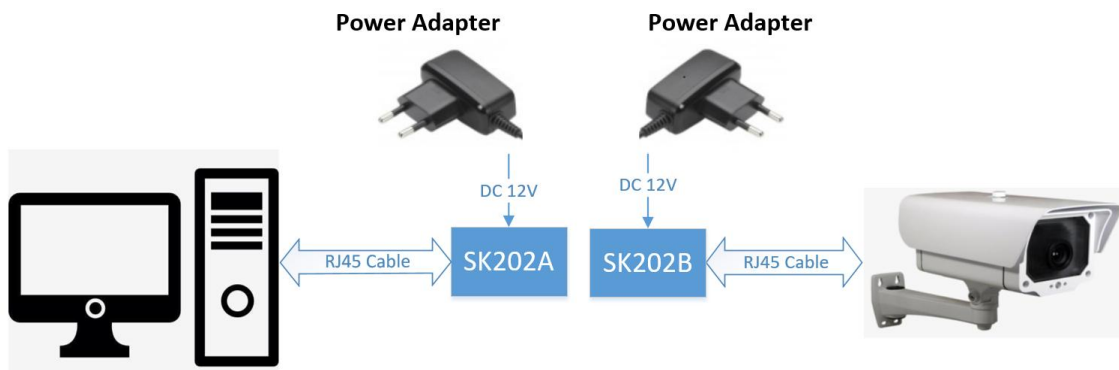

Figure 1. Schematic diagram of using SK202 to connect IP camera

SK202 only needs to be connected to the network and power supply, but it should be noted that the network negotiation rate of the PC side and the router side are the same. If the PC side is a gigabit network, the rate automatically negotiated with the SK202A will be 1G. Then the rate on the router side must be 1Gbps, and the router will automatically negotiate the rate with the SK202B to be 1Gbps. The network will be connected, working on Gigabit Ethernet.

Assuming that the router has a rate of 100M, SK202B will negotiate a rate of 100M with the router. At this time, the rate of SK202A is 1Gbps, and the rates of SK202A/B are inconsistent, and the network will not work. Please refer to section ‘Controlled Auto-negotiation’ below.

The category of the cables used to connect the modules to the rest of the network must be compatible with the rate that will be negotiated. 10/100 or 1000Mbps. Please note that SK202A and SK202B must be used in pairs, and the golden antenna part needs to be aligned with a distance of about 3cm.

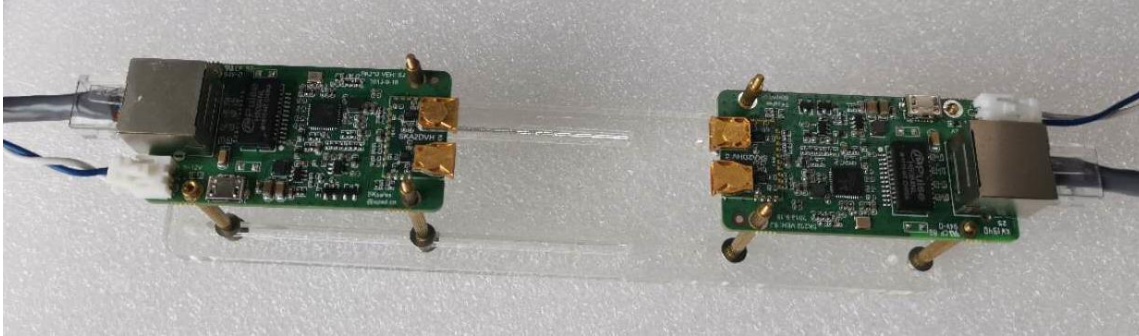

Figure 2. Physical picture of SK202 non-contact connector

### 3. Controlled Auto-negotiation

The Network PHY chip embedded in the SK202 is set in Auto-negotiation mode and is able to support 10/100/1000Mbps. In order for the SK202A and SK202B to communicate they must operate at the same speed. The Yellow LED on the RJ45 connector of blinks when a 1Gbps communication is established between the local and the distant PHY. The Green LED blinks when the communication is at 100Mbps. The Green and Yellow LED all blinks when the communication is at 10Mbps.

The PHYs on the SK202 work independently and each one negotiates automatically with the device it is connected to. So two independent negotiations take place in parallel.

As a consequence, if the two devices, such as a laptop and a camera, advertise different maximum speeds, the two auto-negotiation results will differ.

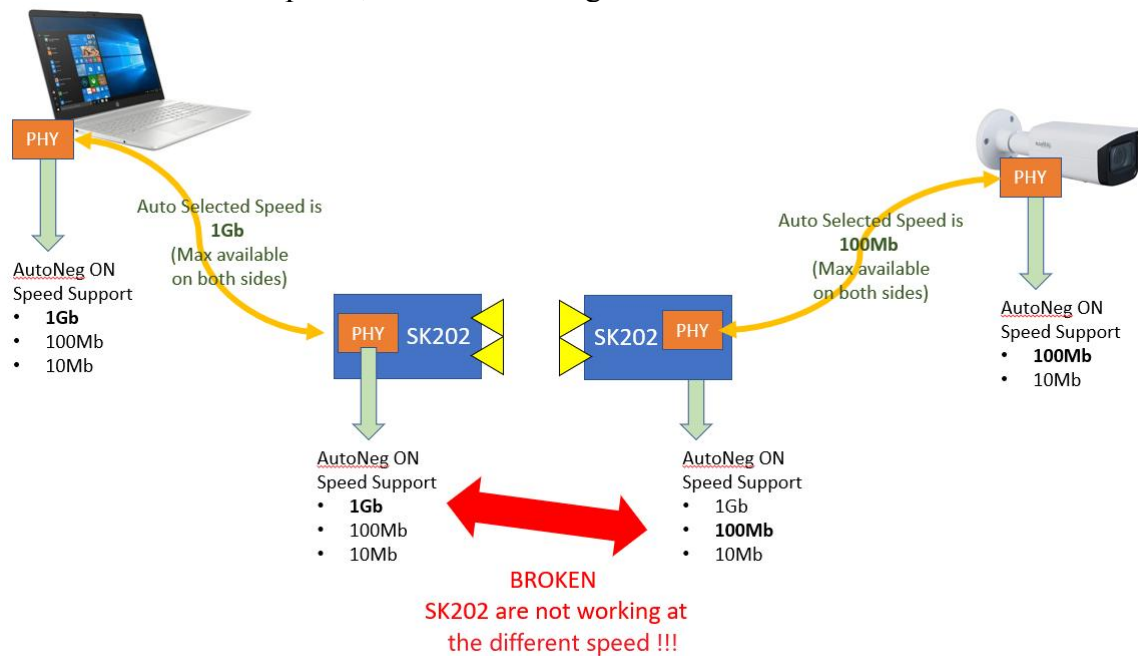

Figure 3. Non controlled auto-negotiation may fail

**For the SK202 communication to establish correctly between devices advertising different maximum speed capabilities, the auto-negotiation of the**

**fastest device has to be controlled.**

Thanks to the controlled auto-negotiation on the laptop, one can ensure the link with the SK202 will be set up at the same speed than the one between the second SK202 and the camera.

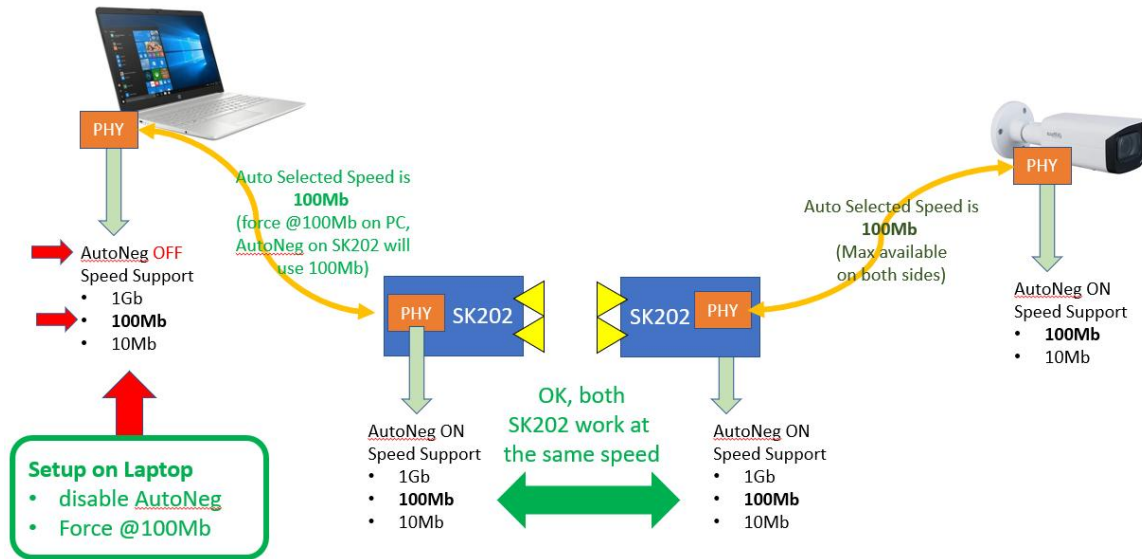

Figure 4. Controlled auto-negotiation is required when the 2 devices do not advertise the same maximum speed capability

Alternatively, one can introduce a switch operating at the same speed than the slowest device in order to ensure the auto-negotiation result will be the same on both sides.

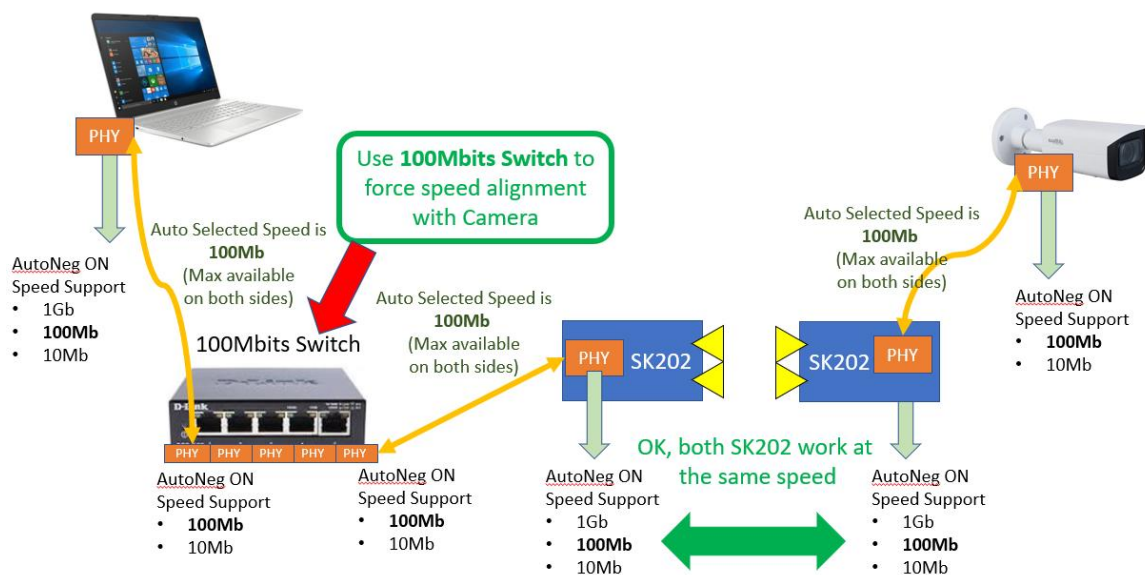

Figure 5. Auto-negotiation result controlled using a switch.

## 4. Performance evaluation method

If you need to evaluate the impact of SK202 on network transmission, it is recommended to use a third-party tool IPERF3. Only need two network cable and two PCs to complete the test. You can download from the address as below:

<https://iperf.fr/iperf-download.php>

Iperf3 test method:

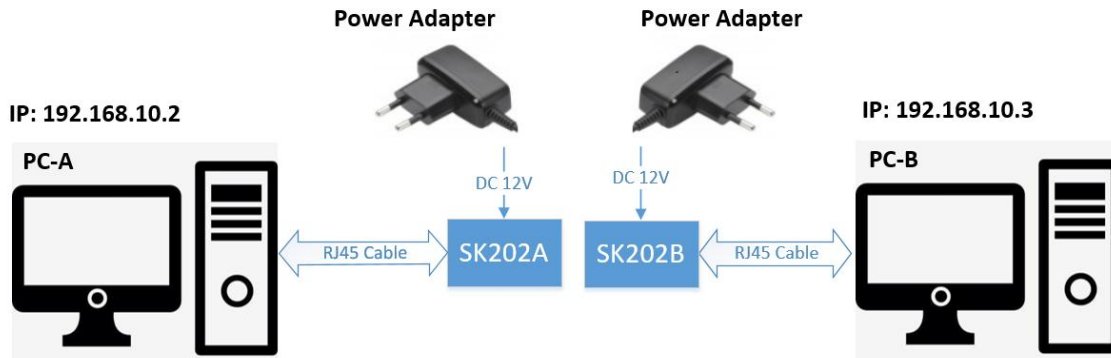

Figure 6. Iperf3 test Schematic diagram with SK202

Refer to the figure 6 to connect to the network. The network adapters of two PCs need the same speed, such as Gigabit Ethernet controller. IP address of PC-A is set to 192.168.10.2, IP address of PC-B is set to 192.168.10.3. Please use at least Cat5e-type cable for testing

PC-A as a server, run command: `iperf3 --server`

PC-B as client, run command: `iperf3 --udp --bandwidth 1G --client 192.168.10.2 --time 100 --len 63k`

IPERF3 will test 100 seconds through UDP protocol with 1G bandwidth, and there will be BER and jitter result output as the blow picture.

At server side:

```

-----
[ ID] Interval          Transfer    Bandwidth    Jitter    Lost/Total Datagrams
[  5]  0.00-100.00 sec  0.00 Bytes  0.00 bits/sec  0.099 ms  0/184761 (0%)
-----

```

At client side:

```

-----
[ ID] Interval          Transfer    Bandwidth    Jitter    Lost/Total Datagrams
[  4]  0.00-100.00 sec  11.1 GBytes  954 Mbits/sec  0.099 ms  0/184761 (0%)
[  4] Sent 184761 datagrams

```

iperf Done.

If you care about the output of iperf3 test, a comparison test is necessary. You can change the SK202 modules to a RJ45 connector to directly connect two PCs, and use the same command for comparison test.

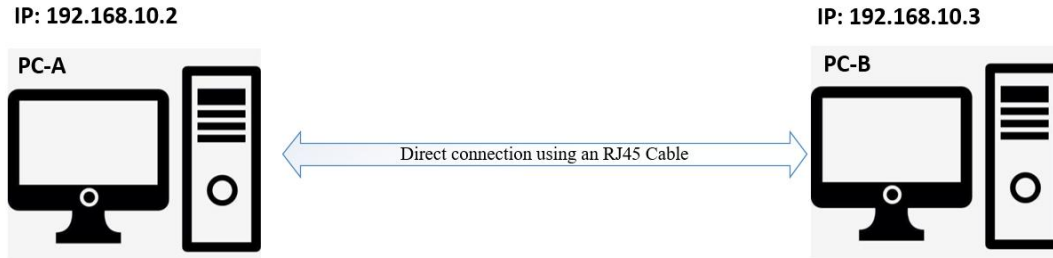

Figure 7. Iperf3 test Schematic diagram with RJ45 cable

## 5. Environment constraints

For the RF waves to propagate correctly from one module to the other, care must be taken not to introduce any metallic obstacle in a Keep Out Area (KOA), in green on the figures below. This KOA is a parallelepiped of 22 mm width and 9 mm height. The length being the distance between the antennae, usually 30 mm.

Moreover, a Safe Area has been defined, in orange on the figures below. The elements present in this area may have an impact on the millimeter waves propagation.

This Safe Area is a parallelepiped of 60 mm width and height. The length being the distance between the antennae, usually 20 mm.

In case an electronic component, a metal part, a fastener, a screw, some metal paint or any sort of reflective surface resides in this volume, its impact must be analyzed.

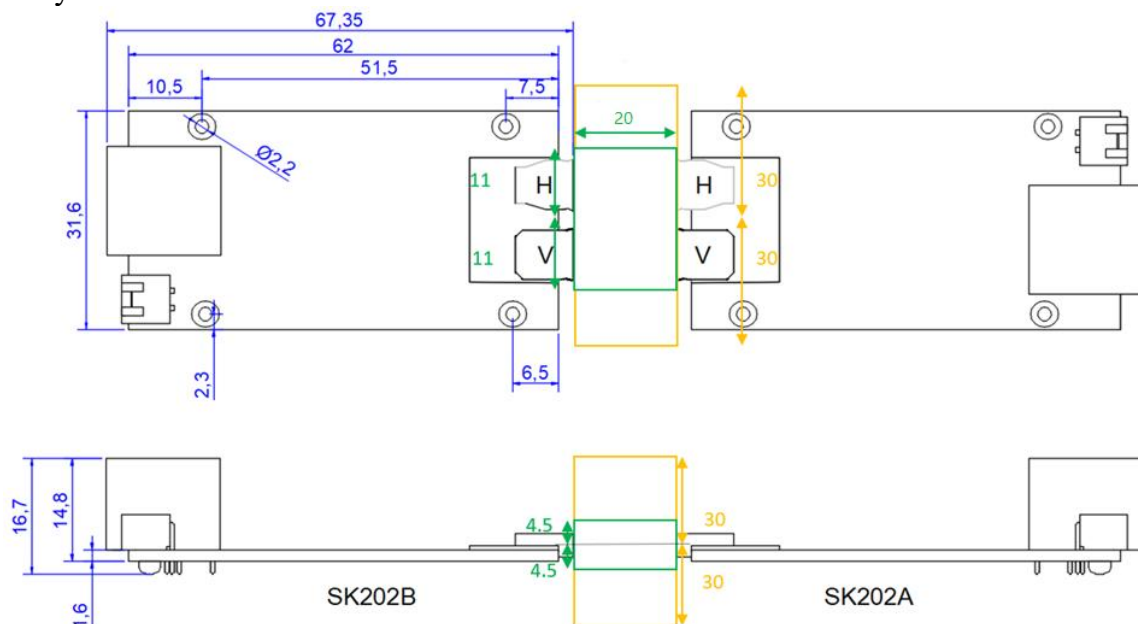

Figure 8. Keep Out Area (Green) and Safe Area (Orange)

In case a metallic casing is to be used around the modules, it is mandatory to insert an opening for the millimeter waves to propagate. This opening may be filled

with ABS or other microwave insensitive materials to maintain water tightness. This opening should follow these guidelines:

- The casing must be placed at around 2.7mm from the PCB to ensure a free space of 0.8mm between the Horn antennae body and the ABS housing.
- The opening should be minimum 22 mm long and 9 mm wide, centered on the 2 antennae, but it can be enlarged.
- Should the casing be placed further than 2.7mm from the PCB, the opening dimensions will have to be adjusted to prevent reflections.

This is summarized in the figure below:

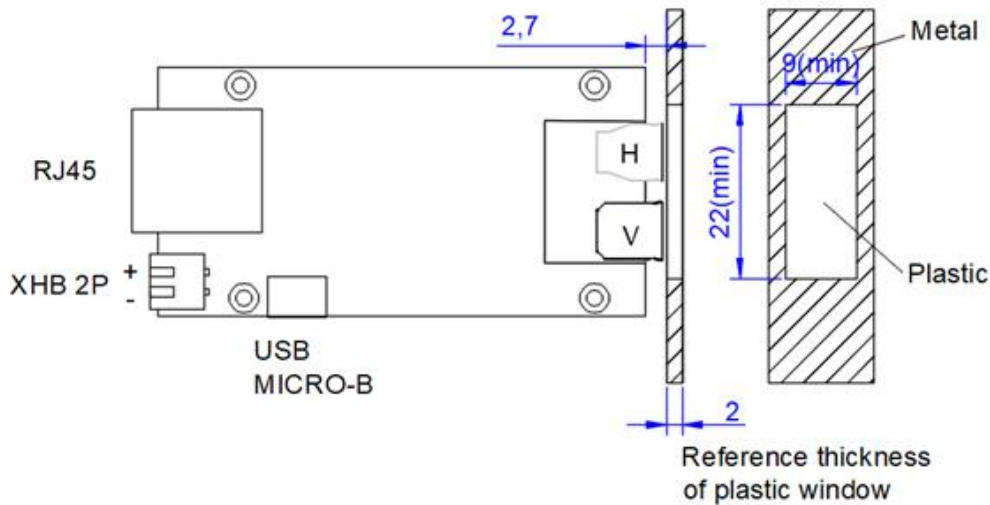

Figure 9. Opening in a metallic housing

## 6. Characteristics

Recommended operating conditions and electrical characteristics

Symbol	Description	Minimum	Typical	Maximum	Unit
$V_{IN}$	Power supply	4.4	12	16	V
$C_{IN}$	Input current(*)	-	50	80	mA
P	Total Power consumption	-	0.6	-	W
$T_A$	Ambient Operating Temperature, for SK202AC/BC	0	-	70	°C
$T_A$	Ambient Operating Temperature, for SK202AI/BI	-40	-	85	°C
$T_J$	Maximum Junction Temperature	-	-	125	°C
$T_{STG}$	Storage Temperature	-40	-	105	°C
$L_{C1}$	Working distance at 50°C, for SK202AC/BC	1.0	2.0	4.5	cm
$L_{C2}$	Working distance at 0°C, for	1.0	2.0	5.5	cm

	SK202AC/BC				
L <sub>I</sub>	Working distance at 85 °C, for SK202AI/BI	1.0	2.0	3.5	cm
Fosc	Carrier Frequency	60.3	60.4	60.5	GHz
EIRP	Output EIRP	4	6	8	dBm

\* when power supply is 12V and Ethernet is active.

## 7. RF certification

FCC Part 15:

This equipment has been tested and found to comply with the limits for a Class B digital device, pursuant to Part 15 of the FCC Rules.

These limits are designed to provide reasonable protection against harmful interference in a residential installation. This equipment generate, uses and can radiate radio frequency energy and, if not installed and used in accordance with the instructions, may cause harmful interference to radio communications.

However, there is no guarantee that interference will not occur in a particular installation. If this equipment does cause harmful interference to radio or television reception, which can be determined by turning the equipment off and on, the user is encouraged to try to correct the interference by one of the following measures:

- Reorient or relocate the receiving antenna.
- Increase the separation between the equipment and receiver.
- Connect the equipment into an outlet on a circuit different from that to which the receiver is connected.
- Consult the dealer or an experienced radio/TV technician for help.

This device complies with Part 15 of the FCC Rules. Operation is subject to the following two conditions:

(1) This device may not cause harmful interference, and (2) this device must accept any interference received, including interference that may cause undesired operation.

FCC Caution: Any changes or modifications not expressly approved by the party responsible for compliance could void the user's authority to operate this equipment.

RF exposure warning

This equipment complies with FCC radiation exposure limits set forth for an uncontrolled environment.

This product may not be collocated or operated in conjunction with any other antenna or transmitter

This equipment must be installed and operated in accordance with provided instructions and the antenna(s) used for this transmitter must be installed to provide a separation distance of at least 20 cm from all persons and must not be collocated or operating in conjunction with any other antenna or transmitter.

### Revision History

Date	Version	Changes
Jun 01 2026	1.4	Update Net LED
APR 19 2022	1.3	Fixed bugs in figure3
MAR 17 2021	1.2	Update Net LED
JAN 08 2021	1.1	Update Characteristics and FCC Part
NOV 02 2020	1.0	Initial Release